

Hydraulic Couplers



Standardly manufactured with 4 punched and hardened jaws that are designed for longevity under high pressure.

For use with standard hydraulic grease nipples acc. to DIN 71412, and SAE specification.

This coupler works with all grease gun types.

All components are manufactured and designed for heavy duty industrial applications.



upon request
also available with
turned jaws

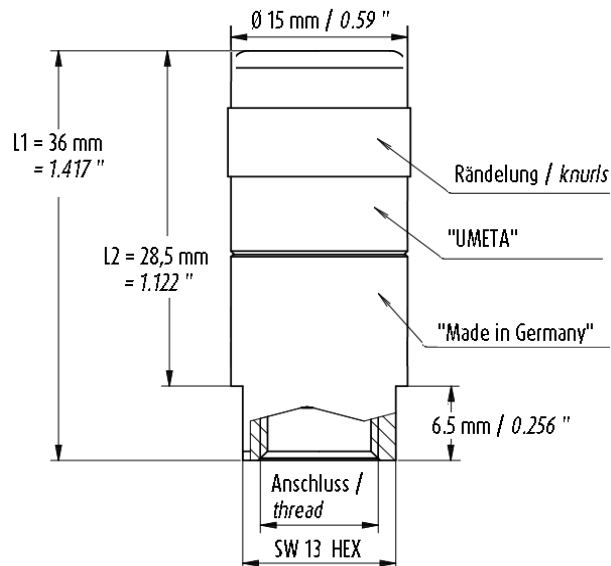
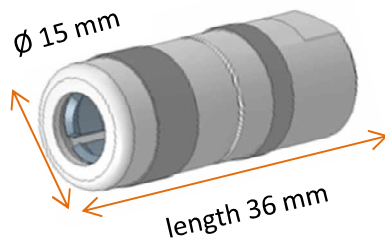

Technical Details

- 4 hardened jaws - for less wear and high longevity
- works on - all metric (DIN) and SAE specification hydraulic grease nipples
- works with - alle grease gun types (manual ~, pneumatic~ and battery powdered~)
- compact design - enables access to difficult to reach lube points
- working pressure - 400 bar
- testing pressure - 800 bar

Instructions for use

- plug on as straight as possible
- once there is a little pressure on the system, the coupler sticks very tight to the grease nipple
- To loose the coupler please do not tear it in straight direction but loose it with rotating actions off the grease nipple.



Using with

- Standard accessories - like high-pressure hoses and nozzle tubes



- as standard connection - with coupler for quick-connectors



eg.:



Hydraulic coupler



standardly with punched jaws
suitable for hydraulic-type nipples acc. to DIN 71412 and SAE
Ø 15 mm
height 36 mm
wrench size 13

Type	Connection	Ref. No.:
515/G	M 9 x 1	7353361
	M10 x 1	V000077
	G 1/8	V000106
	1/8 NPT	V000102

Angled hydraulic coupler 90°



standardly with punched jaws
suitable for hydraulic-type nipples acc. to DIN 71412 and SAE
Ø 15 mm
height 36 mm
width 27 mm
wrench size 14

Type	Connection	Ref. No.:
515/G-S	M10 x 1	7351314
	G 1/8	7351315
	1/8 NPT	7351317

Hydraulic coupler, oil-proof and heavy-duty hexagon



standardly with punched jaws
with ball valve - therefore, absolutely oil-proof
suitable for hydraulic-type nipples acc. to DIN 71412 and SAE
Ø 15 mm
height 48 mm
wrench size 17

Type	Connection	Ref. No.:
512/G	M10 x 1	7351316
	G 1/8	7351326
	1/8 NPT	7351376

Hydraulic coupler - oil-proof



standardly with punched jaws
with ball valve - therefore, absolutely oil-proof
suitable for hydraulic-type nipples acc. to DIN 71412 and SAE
Ø 15 mm
height 36 mm
wrench size 13

Type	Connection	Ref. No.:
515/G-O	M10 x 1	V000330
	G 1/8	V000361
	1/8 NPT	V000239